



Dongguan Taizhang Machinery Co., Ltd  
 ADD : No. 10, Gongxing Road , Chashan Town, Dongguan City,  
 Guangdong Province, China  
 TEL : 0769-86869048 /9 FAX : 0769-85325873

## Sales Quote

Demand side	Supplier	Dongguan Taizhang Machinery Co., Ltd.
Purchaser	Quotation Provider	Mr. Chen
Contact Details	Contact Details	13825751533
address	address	No. 10, Gongxing Road, Chashan Town, Dongguan City, Guangdong Province

**Thank you for your support and trust in our company. The quotation for the products you need is as follows:**

### 1. Equipment Content and Quotation

name	model	quantity	Unit Price ( USD )	Total Price ( USD )
L750 PP Sheet Line	TANZ-120PP	1 set	152,378	152,378
<b>total</b>	USD 152,378			

### 2. Equipment List

Serial number	project	quantity
1	One to two vacuum loader	1 unit
2	Quantitative feeder (with masterbatch machine)	1 set
3	120 single screw PP extruder (capacity 200-350kg/h)	1 set
4	Screen Changer	1 set
5	Melt metering pump	1 set
6	Die head/900mm width, die head opening 0.2-2.0mm	1
7	Three-roll calender L=1000mm	1 set
8	Roller temperature control system	1 set
9	Cooling rack	1 unit
10	Circular knife trimming device + waste edge winding device (on both sides)	1 set
11	Online oiling device + oven (double-sided)	1 set
12	Tension traction machine	1 unit
13	Servo Winder (Double Station)	1 unit
14	Complete line electrical control system	1 set



## L750 PP Sheet Line

----Technical solution

### 1 . Project Overview

raw material	PP Granules/Flakes
Product specifications	A single-layer PP sheet, the finished sheet width is 750 mm (width is adjustable), the sheet thickness is 0.2-2.0 mm (thickness is adjustable)
Process	PP single-layer sheet line ( a kind of sheet product that is plasticized and extruded by an extruder , dehydrated, filtered, extracted, extruded into a mold, calendered and cooled , and extruded into a sheet product, and can be synchronously coated with oil on the surface , and rolled up to a certain specification on the reel at the back end.
Host Specifications	120PP extrusion machine
Extrusion form	Single layer extrusion line
Yield	200-350kg/h

Equipment 3D reference image:

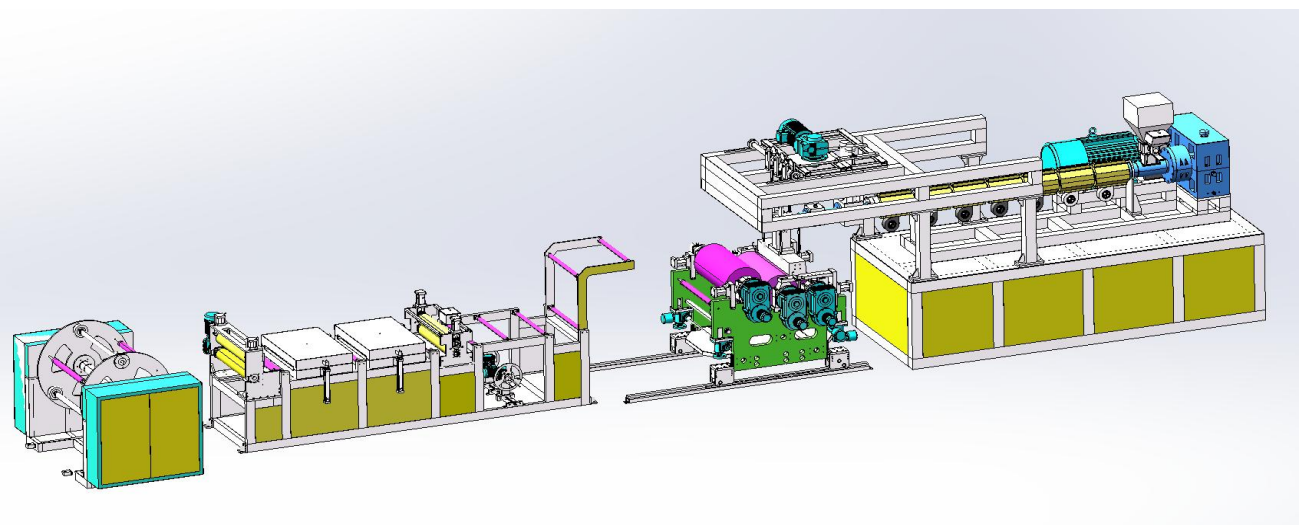



Dongguan Taizhang Machinery Co., Ltd  
ADD : No. 10, Gongxing Road , Chashan Town, Dongguan City,  
Guangdong Province, China  
TEL : 0769-86869048 /9 FAX : 0769-85325873

## 2. Working conditions

Warehouse/Workshop	Required floor space dimensions: 30m (length) × 6m (width) × 3.5m (height) . Includes ( foundation, building works, earthwork and wall works construction. Crane, forklift or other )
power supply	Three-phase, 380V, 50 Hz
Wires/Cables/Pipes	Wires/cables from the power supply to the control cabinet of this production line; all cables from the control cabinet to each machine. Water pipes: supply water to machines and pools.
Cooling water	No dissolved or suspended minerals such as phosphorus, sulfur, iron, etc. Inlet water temperature T1: Maximum 15°C; Outlet temperature T2: T2=T1+5°C; Hardness: 5-8odH
lubricating oil	ExxonMobil
compressor	Supply compressed air

## 2. Energy consumption

Installed power	About 220KW (actual power consumption percentage: 70%)
Cooling water	~1.5M3/hr, ≤30°C, ≥0.3Mpa
Compressed air	1.5/m3/min, 0.5~0.8Mpa
Support staff	1 person

## 3. Host size diagram (for reference)

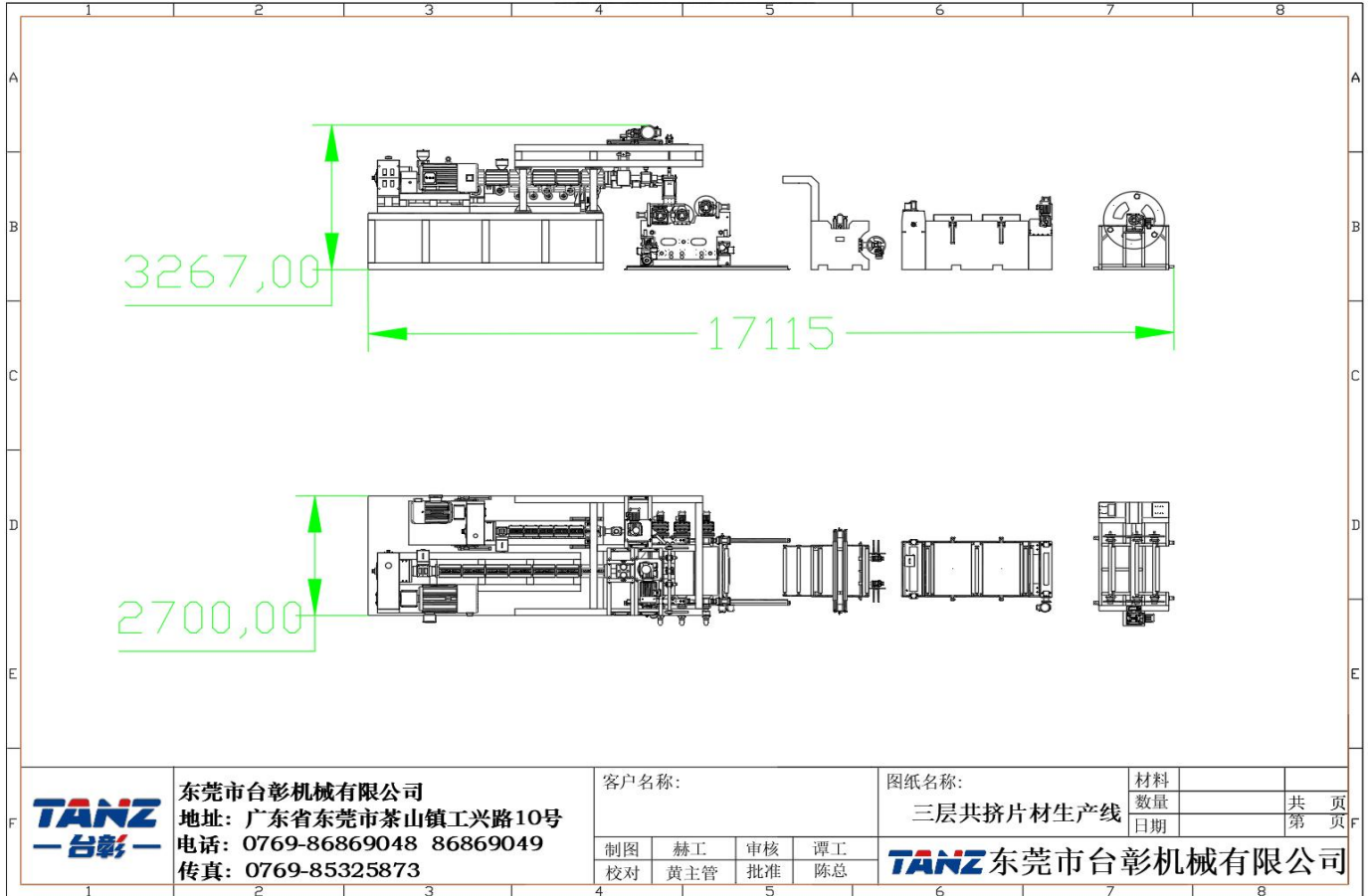

### 4. Technical parameters

#### No. 1

One to two vacuum loader      Feeding power: 7.5KW  
 Feeding speed: 600-800kg/h  
 Feeding method: vacuum feeding  
 Feeding points: one to two

#### No. 2

Quantitative feeder (with      Feeding form: quantitative synchronous feeding  
 masterbatch machine)      Feeding speed: Synchronous with the host machine or independently controlled  
 Motor power: 2.2KW  
 Masterbatch feeding method: Synchronous with the host machine or independently  
 controlled  
 Hopper material: ISUS stainless steel

#### No. 3



Dongguan Taizhang Machinery Co., Ltd  
ADD : No. 10, Gongxing Road , Chashan Town, Dongguan City,  
Guangdong Province, China  
TEL : 0769-86869048 /9 FAX : 0769-85325873

120 single screw extruder/with  
vacuum pump (capacity  
200-350kg/h)

Screw structure: single screw (with exhaust)  
Screw diameter:  $\Phi$  120 mm  
Screw aspect ratio : L/D = 35  
Screw material : 38CrMoA1A  
Screw surface treatment: Nitriding treatment  
Barrel material : 38CrMoA1A  
Barrel heating method and power : Ceramic heating + about 50KW  
Barrel heat protection : stainless steel protective cover  
Cooling method: fan cooling  
Main drive motor : AC90 KW (Siemens motor /Dongguan motor )  
Gear reducer: gear reducer for extruder  
Exhaust vacuum system: three-stage vacuum pump vacuum  
Self-protection system : motor overload protection , screw pressure protection ,  
high temperature protection  
Intelligent control system : PLC control system, closed-loop control, automatic data  
tracking

## No. 4

Screen Changer

**Structure:** Plate type  
**Model:** 150  
**Drive system:** Hydraulic drive  
**Heating method:** stainless steel heating tube heating  
**Hydraulic system:** equipped with oil tank, oil pump, reversing valve, oil cylinder,  
hydraulic circuit, etc.

## No. 5

Melt metering pump

**Model :** 200CC  
**Drive mode:** servo drive  
**Drive reducer:** Beiji  
**Motor power :** 7.5KW  
**Speed control :** Synchronous with the host or independent control  
**Drive connection:** Universal coupling



**Melt pressure sensor:** The melt pressure sensor is installed in front of the screen changer, in front of the metering pump and behind the metering pump.

## No. 6

Die head/900mm width, die head opening 0.2-2.0mm

Installation method: hanger installation

Mold structure: T- type die head, hanger-type flow channel

**Mould width: 900mm**

**Product effective width: 750mm**

**Die lip opening : 0.2-2.0mm**

**Die lip adjustment method:** mechanical adjustment

**Manufacturing process : Overall quenching and tempering, flow surface hard chrome plating and polishing, the thickness of the chrome layer after polishing is 0.03-0.05mm**

## No. 9

Three-roll calender (front roller is matte sand) L=1000mm

1 # roller : 320 \* 1000mm

2 # roller : 500 \* 1000mm

3# roller : 500 \* 1000mm

**Roller material:** Carbon steel, tempered and hardened, surface electroplated, super mirror polished

**Roller surface roughness:** Ra≤0.015μm

**Roller surface hardness:** HRC58-62

**Chrome plating thickness:** ≥ 0.08mm

**Roller structure:** special inner spiral channel structure ensures overall consistency

**Roller wall panel :** solid steel plate

Drive motor : Siemens servo motor

Control method : Siemens control system

Motor power: 5.5KW\*3

**Reducer brand:** Guomao/ Dongli/ American Jienuo and other first-line brands

**Roller gap adjustment:** The rollers are opened and closed by hydraulic drive. The gap is adjusted manually by worm gear

**Three roller bearings:** NSK (Japan)

**Swivel joint:** Fujian Minxuan, single-side water inlet and outlet

**Safety measures:** with mechanical fixed limit and pull-wire emergency stop safety switch



Dongguan Taizhang Machinery Co., Ltd  
 ADD : No. 10, Gongxing Road , Chashan Town, Dongguan City,  
 Guangdong Province, China  
 TEL : 0769-86869048 /9 FAX : 0769-85325873

## No. 10

Roller temperature control system  
 Cooling medium: soft water  
**Temperature control range:** 30°C-60°C  
**Temperature control accuracy:** ±1°C  
**Heating power:** 15kw\*3  
**Water pump power:** 3.75kw\*3  
**Safety measures:** With alarm functions for overpressure, overtemperature, water shortage, etc.

## No. 11

Cooling rack  
**Cooling support structure:** frame structure  
**Roller material:** Aluminum roller, surface anodized, polished  
 Roller size : Φ 800\*1000mm

## No. 12

Circular knife trimming device + waste edge winding device (on both sides)  
**Trimming device: 2 sets (on both sides)**  
**Cutting method: disc cutting**  
**Scrap take-up unit:** 2 sets of rotor blades, easy to adjust  
**Scrap winding machine:** Independent control , torque motor

## No. 13

Online oiling device + oven (double-sided)  
**Coating roller material:** Silica gel  
**Fuel tank material:** Stainless steal stainless steel  
 Oiling method: dripping  
**coating method :** double-sided or single-sided oil coating  
**Adjustment method:** Cylindrical  
**Oven unit :** 2 groups  
 Oven size: 800 \* 1000mm  
**Heating method:** heating tube  
**Heating power:** 1 5 kw\* 2 sets  
**Temperature control method:** Temperature controller (Omron)

## No. 14

Tension traction machine  
**Traction method:** roller type  
**Roller material:** Upper roller: rubber roller ; Lower roller: mirror steel roller  
**Roller size (quantity):** Φ200\*1 0 00mm (2 pieces)  
**Motor specification:** 3 kw servo motor



Dongguan Taizhang Machinery Co., Ltd  
ADD : No. 10, Gongxing Road , Chashan Town, Dongguan City,  
Guangdong Province, China  
TEL : 0769-86869048 /9 FAX : 0769-85325873

**Control method: Huichuan**

**Reducer brand:** Guomao/ Dongli/ American Jienuo and other first-line brands

**Speed control : servo control**, can be synchronized with the three-roll calender or work alone

## No. 17

Servo Winder

**Number of workstations: double workstations**

Rolling specifications: product width 1000mm, maximum roll diameter 500mm

Control mode: PLC

Drive control mode: servo drive

Servo motor : **Inovance Technology**

Length control: Automatic meter counter

**Winding motor: 3KW servo motor**

## No. 18

Complete line electrical control system

Control system: Mitsubishi

Contactora : Schneider, France

Inverter: Inovance Technology

Relay : Omron/Izumi, Japan

Servo: Inovance Technology

Driver: Inovance Technology

Control module: Taiwan Delta

Switching power supply: Taiwan Mean Well

Photoelectric switch: Taiwan Mean Well

Temperature sensor: Taiwan Hualing

Push button switch: Japanese Izumi

Roller safety switch: Pizzato, Italy

Air switch : CHINT

Pneumatic components: AirTac/Japan SMC

Cabinet cooling method: fan cooling

### spare parts

Heating coil, thermocouple: 1 set

Trimming circular knife: 1 set

Mould disassembly and assembly tools: 1 set

Strong magnet for raw material feed port: 1 set



# **TANZ** Dongguan Taizhang Machinery Co., Ltd.

**Ltd.**

Dongguan Taizhang Machinery Co., Ltd

ADD : No. 10, Gongxing Road , Chashan Town, Dongguan City,  
Guangdong Province, China

TEL : 0769-86869048 /9 FAX : 0769-85325873

---

